

Plastic-Encapsulate Diodes

ZENER DIODE

FEATURES

- Planar Die Construction
- 150mW Power Dissipation
- Zener Voltages from 2.4 – 39V
- Ideally Suited for Automated Assembly Processes

PINNING

| PIN | DESCRIPTION |
|-----|-------------|
| 1 | Cathode |
| 2 | Anode |

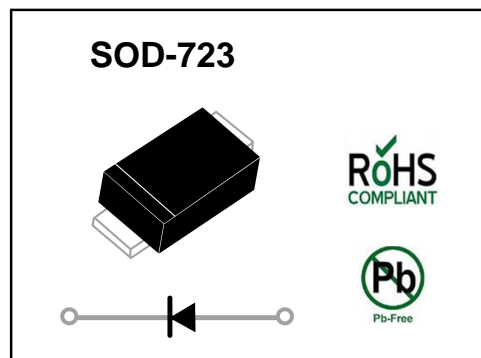

Maximum Ratings($T_a=25^{\circ}\text{C}$ unless otherwise specified)

| Characteristic | Symbol | Value | Unit |
|--|-----------------|----------|----------------------|
| Forward Voltage | V_F | 0.9 | V |
| Power Dissipation (Note 1) | P_D | 150 | mW |
| Thermal Resistance from Junction to Ambient | $R_{\theta JA}$ | 833 | $^{\circ}\text{C/W}$ |
| Operation Junction and Storage Temperature Range | T_J, T_{STG} | -55~+150 | $^{\circ}\text{C}$ |

ELECTRICAL CHARACTERISTICS

T_a=25°C unless otherwise specified

| Type Number | Type Code | Zener Voltage Range (Note 2) | | | | Maximum Zener Impedance (Note 3) | | | Maximum Reverse Current | | Typical temperature coefficient @ I _{ZT} mV/°C | |
|-------------|-----------|---------------------------------|--------|--------|-----------------|----------------------------------|----------------------------------|------|-------------------------|----------------|---|------|
| | | V _Z @I _{ZT} | | | I _{ZT} | Z _{ZT} @I _{ZT} | Z _{ZK} @I _{ZK} | | I _R | V _R | Min | Max |
| | | Nom(V) | Min(V) | Max(V) | (mA) | (Ω) | (mA) | (uA) | (V) | | | |
| BZX784C2V4 | Z1 | 2.4 | 2.20 | 2.60 | 5 | 100 | 600 | 1.0 | 50 | 1.0 | -3.5 | 0 |
| BZX784C2V7 | Z2 | 2.7 | 2.5 | 2.9 | 5 | 100 | 600 | 1.0 | 20 | 1.0 | -3.5 | 0 |
| BZX784C3V0 | Z3 | 3.0 | 2.8 | 3.2 | 5 | 95 | 600 | 1.0 | 10 | 1.0 | -3.5 | 0 |
| BZX784C3V3 | Z4 | 3.3 | 3.1 | 3.5 | 5 | 95 | 600 | 1.0 | 5 | 1.0 | -3.5 | 0 |
| BZX784C3V6 | Z5 | 3.6 | 3.4 | 3.8 | 5 | 90 | 600 | 1.0 | 5 | 1.0 | -3.5 | 0 |
| BZX784C3V9 | Z6 | 3.9 | 3.7 | 4.1 | 5 | 90 | 600 | 1.0 | 3 | 1.0 | -3.5 | 0 |
| BZX784C4V3 | Z7 | 4.3 | 4.0 | 4.6 | 5 | 90 | 600 | 1.0 | 3 | 1.0 | -3.5 | 0 |
| BZX784C4V7 | X1 | 4.7 | 4.4 | 5.0 | 5 | 80 | 500 | 1.0 | 3 | 2.0 | -3.5 | 0.2 |
| BZX784C5V1 | X2 | 5.1 | 4.8 | 5.4 | 5 | 60 | 480 | 1.0 | 2 | 2.0 | -2.7 | 1.2 |
| BZX784C5V6 | X3 | 5.6 | 5.2 | 6.0 | 5 | 40 | 400 | 1.0 | 1 | 2.0 | -2.0 | 2.5 |
| BZX784C6V2 | X4 | 6.2 | 5.8 | 6.6 | 5 | 10 | 150 | 1.0 | 3 | 4.0 | 0.4 | 3.7 |
| BZX784C6V8 | X5 | 6.8 | 6.4 | 7.2 | 5 | 15 | 80 | 1.0 | 2 | 4.0 | 1.2 | 4.5 |
| BZX784C7V5 | X6 | 7.5 | 7.0 | 7.9 | 5 | 15 | 80 | 1.0 | 1 | 5.0 | 2.5 | 5.3 |
| BZX784C8V2 | X7 | 8.2 | 7.7 | 8.7 | 5 | 15 | 80 | 1.0 | 0.7 | 5.0 | 3.2 | 6.2 |
| BZX784C9V1 | X8 | 9.1 | 8.5 | 9.6 | 5 | 15 | 100 | 1.0 | 0.5 | 6.0 | 3.8 | 7.0 |
| BZX784C10 | X9 | 10 | 9.4 | 10.6 | 5 | 20 | 150 | 1.0 | 0.2 | 7.0 | 4.5 | 8.0 |
| BZX784C11 | W1 | 11 | 10.4 | 11.6 | 5 | 20 | 150 | 1.0 | 0.1 | 8.0 | 5.4 | 9.0 |
| BZX784C12 | W2 | 12 | 11.4 | 12.7 | 5 | 25 | 150 | 1.0 | 0.1 | 8.0 | 6.0 | 10.0 |
| BZX784C13 | W3 | 13 | 12.4 | 14.1 | 5 | 30 | 170 | 1.0 | 0.1 | 8.0 | 7.0 | 11.0 |
| BZX784C15 | W4 | 15 | 13.8 | 15.6 | 5 | 30 | 200 | 1.0 | 0.1 | 10.5 | 9.2 | 13.0 |
| BZX784C16 | W5 | 16 | 15.3 | 17.1 | 5 | 40 | 200 | 1.0 | 0.1 | 11.2 | 10.4 | 14.0 |
| BZX784C18 | W6 | 18 | 16.8 | 19.1 | 5 | 45 | 225 | 1.0 | 0.1 | 12.6 | 12.4 | 16.0 |
| BZX784C20 | W7 | 20 | 18.8 | 21.2 | 5 | 55 | 225 | 1.0 | 0.1 | 14.0 | 14.4 | 18.0 |
| BZX784C22 | W8 | 22 | 20.8 | 23.3 | 5 | 55 | 250 | 1.0 | 0.1 | 15.4 | 16.4 | 20.0 |
| BZX784C24 | W9 | 24 | 22.8 | 25.6 | 5 | 70 | 250 | 1.0 | 0.1 | 16.8 | 18.4 | 22.0 |
| BZX784C27 | Y1 | 27 | 25.1 | 28.9 | 2 | 80 | 300 | 0.5 | 0.1 | 18.9 | 21.4 | 25.3 |
| BZX784C30 | Y2 | 30 | 28.0 | 32.0 | 2 | 80 | 300 | 0.5 | 0.1 | 21.0 | 24.4 | 29.4 |
| BZX784C33 | Y3 | 33 | 31.0 | 35.0 | 2 | 80 | 325 | 0.5 | 0.1 | 23.1 | 27.4 | 33.4 |
| BZX784C36 | Y4 | 36 | 34.0 | 38.0 | 2 | 90 | 350 | 0.5 | 0.1 | 25.2 | 30.4 | 37.4 |
| BZX784C39 | Y5 | 39 | 37.0 | 41.0 | 2 | 130 | 350 | 0.5 | 0.1 | 27.3 | 33.4 | 41.2 |

Notes: 1. Valid provided that device terminals are kept at ambient temperature.

2. Tested with pulses, period=5ms,pulse width= 300μs.3

.f = 1KHz.

Typical Characteristics

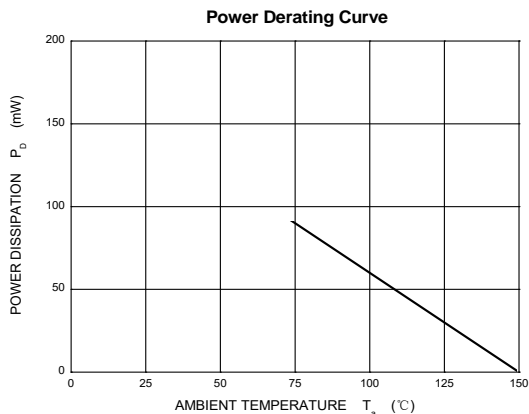
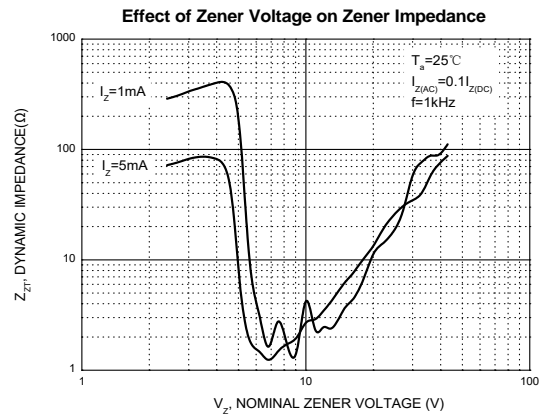
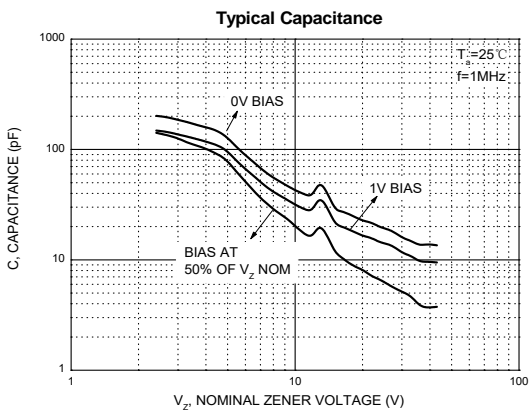
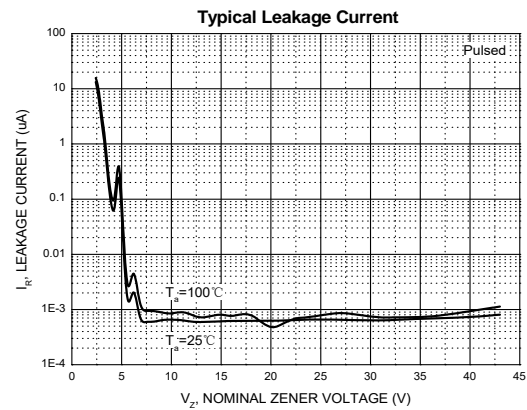
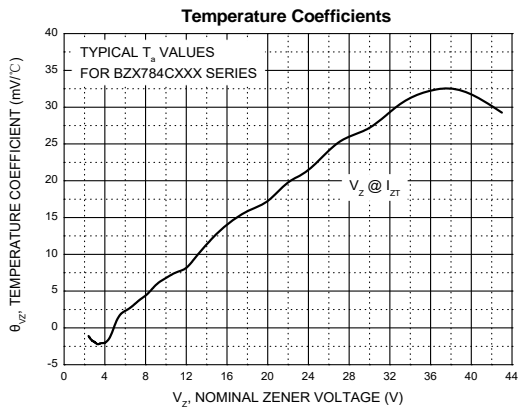
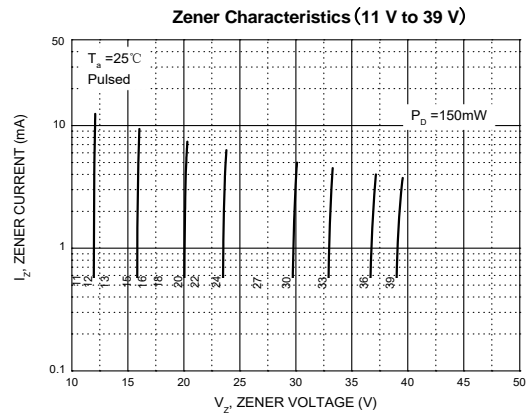
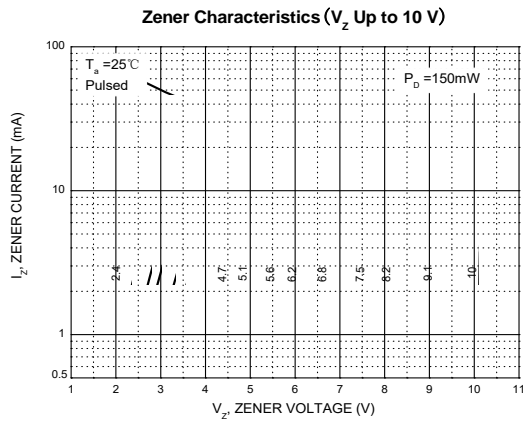

SOD-723 Tape and Reel

SOD-723 Embossed Carrier Tape

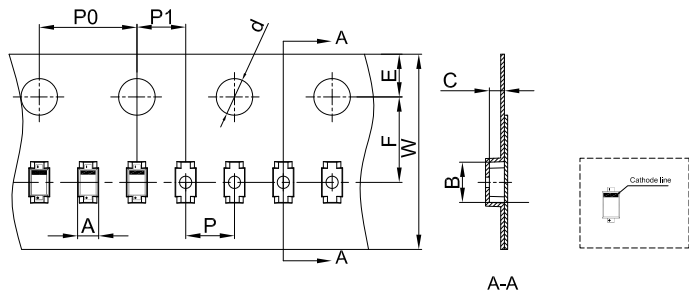

| Dimensions are in millimeter | | | | | | | | | | | |
|------------------------------|------|------|------|-------|------|------|------|------|------|------|--|
| Pkg type | A | B | C | d | E | F | P0 | P | P1 | W | |
| SOD-723 | 0.73 | 1.71 | 0.62 | Ø1.50 | 1.75 | 3.50 | 4.00 | 2.00 | 2.00 | 8.00 | |

SOD-723 Tape Leader and Trailer

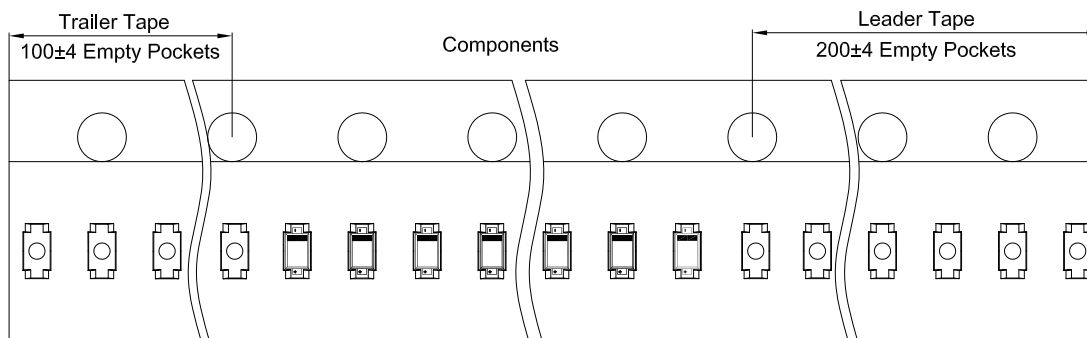

SOD-723 Reel

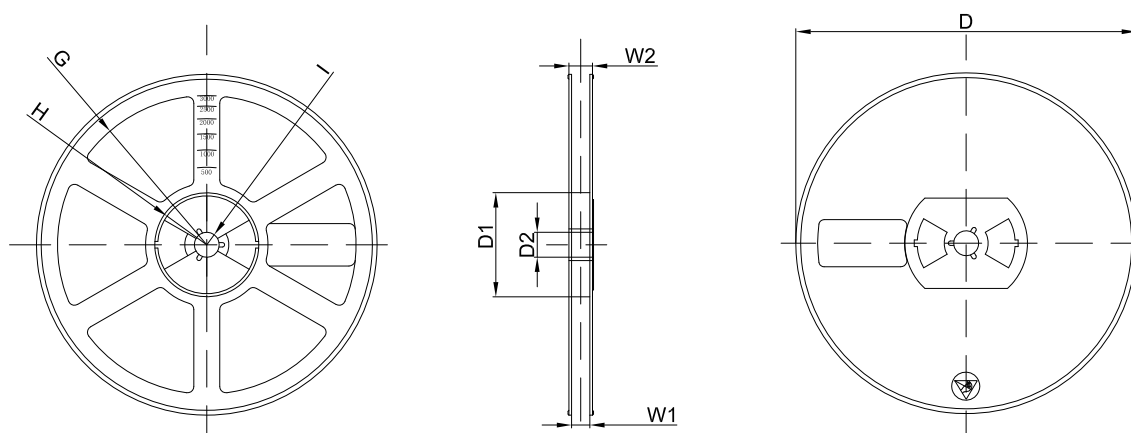

| Dimensions are in millimeter | | | | | | | | |
|------------------------------|---------|-------|-------|--------|--------|-------|------|-------|
| Reel Option | D | D1 | D2 | G | H | I | W1 | W2 |
| 7" Dia | Ø178.00 | 54.40 | 13.00 | R78.00 | R25.60 | R6.50 | 9.50 | 12.30 |

| REEL | Reel Size | Box | Box Size(mm) | Carton | Carton Size(mm) | G.W.(kg) |
|----------|-----------|-------------|--------------|-------------|-----------------|----------|
| 8000 pcs | 7 inch | 120,000 pcs | 203×203×195 | 480,000 pcs | 438×438×220 | |

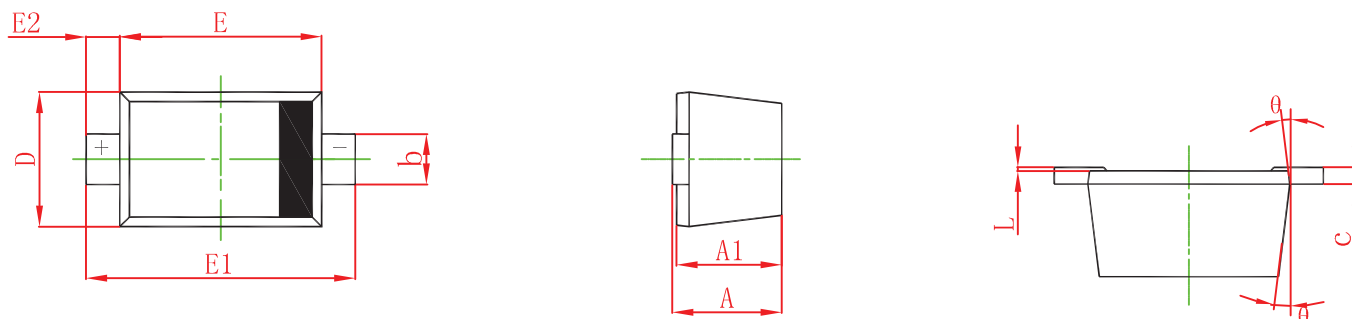

| Symbol | Dimensions In Millimeters | | Dimensions In Inches | |
|----------|---------------------------|-------|----------------------|-------|
| | Min | Max | Min | Max |
| A | 0.525 | 0.650 | 0.021 | 0.026 |
| A1 | 0.515 | 0.580 | 0.020 | 0.023 |
| b | 0.250 | 0.350 | 0.010 | 0.014 |
| c | 0.080 | 0.150 | 0.003 | 0.006 |
| D | 0.550 | 0.650 | 0.022 | 0.026 |
| E | 0.900 | 1.100 | 0.035 | 0.043 |
| E1 | 1.300 | 1.500 | 0.051 | 0.059 |
| E2 | 0.200 REF | | 0.008 REF | |
| L | 0.010 | 0.070 | 0.001 | 0.003 |
| θ | 7° REF | | 7° REF | |

DISCLAIMER

JHG PROVIDES TECHNICAL AND RELIABILITY DATA (INCLUDING DATASHEETS), DESIGN RESOURCES (INCLUDING REFERENCE DESIGNS), APPLICATION OR OTHER DESIGN ADVICE, SAFETY INFORMATION, AND OTHER RESOURCES "AS IS" AND WITH ALL FAULTS, AND DISCLAIMS ALL WARRANTIES, EXPRESS AND IMPLIED, INCLUDING WITHOUT LIMITATION ANY IMPLIED WARRANTIES OF MERCHANTABILITY, FITNESS FOR A PARTICULAR PURPOSE OR NON-INFRINGEMENT OF THIRD PARTY INTELLECTUAL PROPERTY RIGHTS.

These resources are intended for skilled developers designing with JHG products. You are solely responsible for

- (1) selecting the appropriate JHG products for your application;
- (2) designing, validating and testing your application;
- (3) ensuring your application meets applicable standards, and any other safety, security, or other requirements.

These resources are subject to change without notice. JHG grants you permission to use these resources only for development of an application that uses the JHG products described in the resource. Other reproduction and display of these resources are prohibited. No license is granted to any other JHG intellectual property right or to any third party intellectual property right. JHG disclaims responsibility for, and you will fully indemnify JHG and its representatives against, any claims, damages, costs, losses, and liabilities arising out of your use of these resources.